

Lightweight, Rapid Deployment Booms

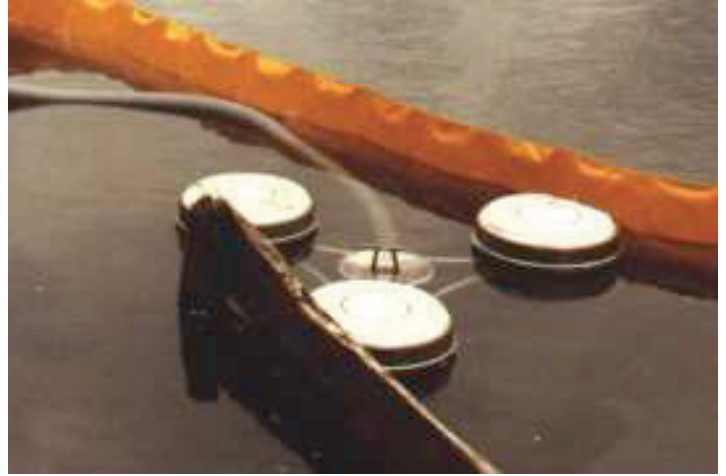

▲ Preventing an oil spill from contaminating a tank.



▲ Preventing floating debris from clogging the skimmer on a pond.

Manufactured from heavy-duty, oil resistant, PVC-coated nylon, the Megator Booms have completely enclosed flotation elements of closed-cell foam. Mild steel weights at the bottom of the skirt are sealed in and the whole exterior presents a smooth surface which is easy to clean. The booms are fitted with eyelets at each end enabling multiple booms to be joined together to cover a greater area. Ideal for use in ponds, lakes, culverts, docks, tanks etc..



Booms fold up for easy storage & transport, yet can be deployed in seconds without the need for inflation or to have weights added.

Specifications

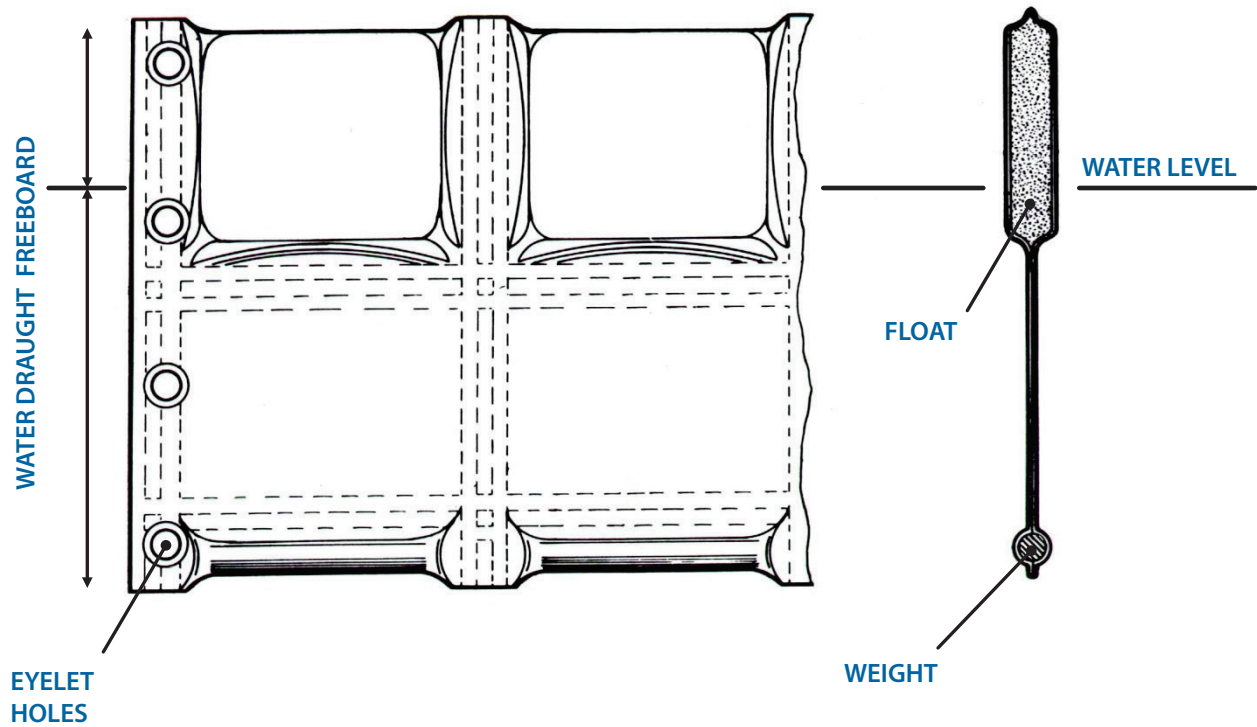

Technical Information

Detail	Mini-boom	Mega-boom
Height	9"	16"
Length	16.5 ft	33 ft
Width	3/4	1-3/16
Freeboard	2"	6"
Water Draught	7"	10"
Float	Foam Cell	Foam Cell"
Material	PVC	PVC
Color	Yellow	Yellow
Total Weight	11 lbs	26 lbs